

YAMAHA B-6

Natural Sound Stereo Power Amplifier

"X" Power Supply Circuit

"X" Power Amplifier Circuit

200 Watts RMS per Channel (8 ohms)

High Power, High Efficiency Amplification

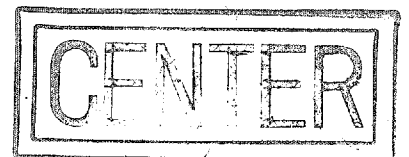

Thank you for purchasing the Yamaha B-6 stereo power amplifier. With the most advanced design techniques available and careful workmanship, Yamaha has created a truly revolutionary amplifier that will bring you the ultimate in audio performance. Please read these instructions through before operating your amplifier and retain this booklet for reference so as to ensure that you will gain the maximum from your B-6 through many years of use.

CONTENTS

CAUTION: READ THIS BEFORE OPERATING YOUR B-6.	2
CONNECTION DIAGRAM.	3
NAMES OF THE PARTS AND THEIR FUNCTIONS.	4
BLOCK DIAGRAM/SPECIFICATIONS.	5
TROUBLESHOOTING.	6

IMPORTANT

Please record the serial number of your unit in the space below.

Model: B-6

Serial No.:

The serial number is located on the bottom of the cabinet. Retain this Owner's Manual in a safe place for future reference.

Special Instructions for British Model

THE WIRES IN THE MAINS LEAD ARE COLOURED IN ACCORDANCE WITH THE FOLLOWING CODE:

Blue: NEUTRAL

Brown: LIVE

As the colours of the wires in the mains lead of this apparatus may not correspond with the coloured markings identifying the terminals in your plug, proceed as follows. The wire which is coloured BLUE must be connected to the terminal which is marked with the letter N or coloured BLACK. The wire which is coloured BROWN must be connected to the terminal which is marked with the letter L or coloured RED.

WARNING

To prevent fire or shock hazard, do not expose this appliance to rain or moisture.

U.S.A. and British Models

The following "CAUTION" label is attached to the cabinet.

CAUTION—TO PREVENT ELECTRIC SHOCK, DO NOT REMOVE COVER OR SCREWS, NO USER-SERVICEABLE PARTS INSIDE. PILOT LAMPS SOLDERED IN PLACE. REFER SERVICING TO QUALIFIED SERVICE PERSONNEL.

B-6 CAUTION: **READ THIS BEFORE OPERATING YOUR B-6**

1 The B-6 is a sophisticated stereo power amplifier. To ensure proper operation for the best possible sound reproduction, please read this manual carefully.

2 Choose the installation location of your B-6 carefully. Avoid placing it in direct sunlight or close to a source of heat. Also avoid locations subject to vibration and excessive dust, heat, cold or moisture.

3 Do not operate the amplifier upside-down as it may overheat, possibly causing damage.

4 Do not open the cabinet as this might result in damage to the set or electrical shock. If a foreign object should get into the set, contact your dealer.

5 Do not place records or other objects against the amplifier so that the ventilation holes are blocked. This will cause the internal temperature to rise and may result in a failure.

6 When removing the power plug from the wall outlet, always pull directly on the plug; never yank the cord.

7 When moving the set be sure to first pull out the power plug and remove cords connecting to other equipment.

8 Before disconnecting input cords from either the B-6 or the control amp, the B-6 should be turned off.

9 Do not clean the B-6 with chemical solvents as this might damage the finish. Use a clean, dry cloth.

10 As the amplifier's power supply generates a certain amount of radio frequency noise, position your tuner so that its AM antenna is well away from the amplifier.

11 Be sure to read the "troubleshooting" section for advice on common operating errors before concluding that your B-6 is faulty.

12 Keep this manual in a safe place for future reference.

The following label is attached to the cabinet of the U.S.A. model.

WARNING—HAZARDOUS ENERGY.
MAKE PROPER SPEAKER CON-
NECTIONS. SEE OPERATING
MANUAL BEFORE USING.

B-6 CONNECTION DIAGRAM

When the B-6 is operated at high power for an extended period of time, its cabinet becomes rather hot. Heat-sensitive materials should be kept away from the amplifier, and it should be installed out of the reach of small children.

IMPORTANT
The maximum audio output power of this appliance having provision for connection of external speakers is not less than 40 watts (R.M.S. 43.8 volts) per audio output channel at 8 ohms load. To prevent electric shock, be sure to turn off the power before connecting the speaker wire. See page 4, speaker connection. If speaker wires are run through building walls or material, class one wiring should be used. For speaker wire use wire with a current rating of at least 6 and VW-1 or FR-1 flame retardant rating.

Connect speaker systems of between 8 and 16 ohms impedance.

It will be easier to connect input and speaker cords if you position the amplifier with the rear panel upward.

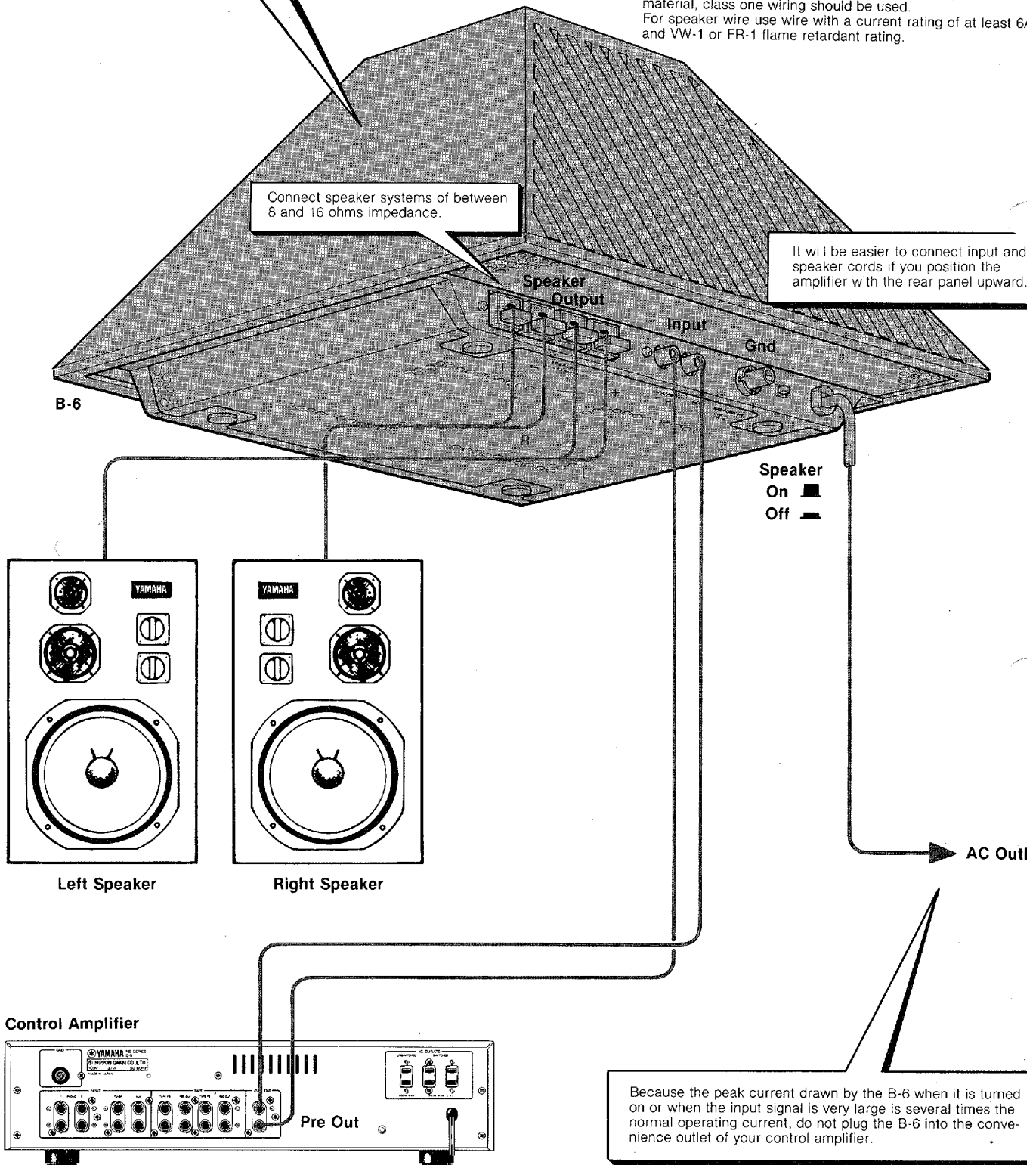

Because the peak current drawn by the B-6 when it is turned on or when the input signal is very large is several times the normal operating current, do not plug the B-6 into the convenience outlet of your control amplifier.

B-6 NAMES OF THE PARTS AND THEIR FUNCTIONS

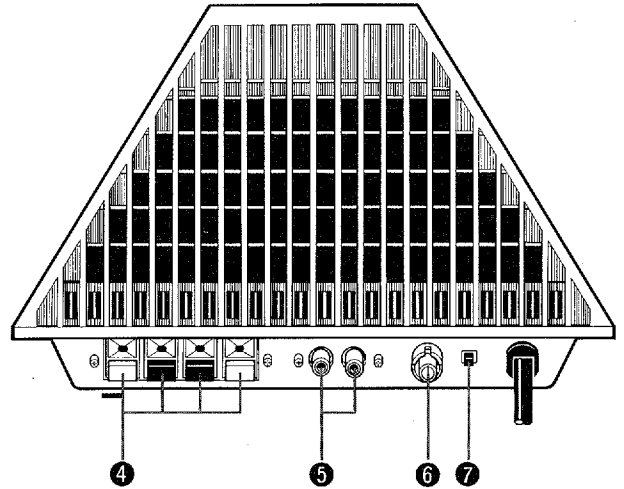
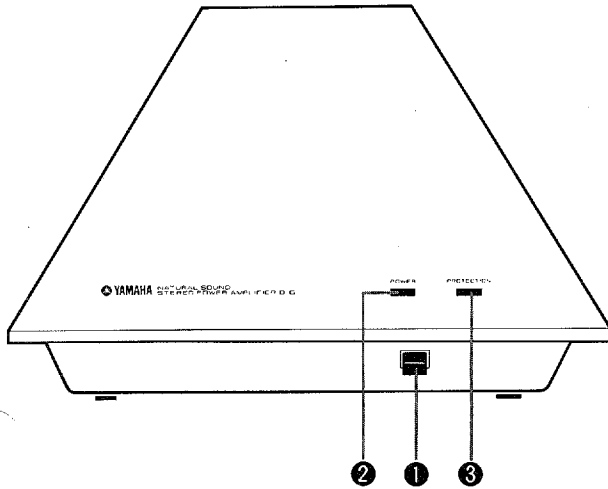

1 POWER SWITCH

This is a "push-on, push-off" type power switch. Be sure to turn the control amplifier's volume control all the way down before turning on the power.

2 POWER INDICATOR

This indicator lights to show that power is turned on.

3 PROTECTION INDICATOR

This indicator lights when for some reason the speaker protection circuit has activated. There will be no sound in this case.

4 SPEAKER TERMINALS

Connect the speaker cords here. The white terminal is the "+" or "hot" side, while the black terminal is the "-" or "cold" side.

5 INPUT TERMINALS

Connect the cords leading from the control amplifier's output terminals here. A control amplifier with a DC offset at its output should not be used.

6 GROUND TERMINAL

Connecting this terminal to ground or to your control amplifier's ground terminal may help eliminate hum or noise problems.

7 SPEAKER SWITCH

This switch turns the speakers on and off. Pushing the switch in (—) turns the speakers off, while pushing it again (■) turns the speakers back on. When power is first applied, a muting circuit temporarily disables the sound regardless of the position of the switch.

1. Push the terminal button and slide the wire in.

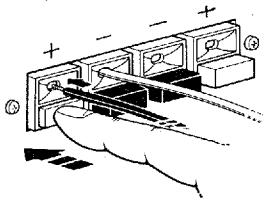

2. Release the button and check to see that the wire is held firmly in place.

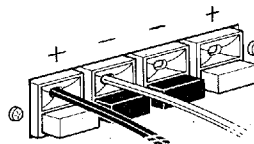

3. Make sure that there is absolutely no possibility of the "+" and "-" wires shorting together.

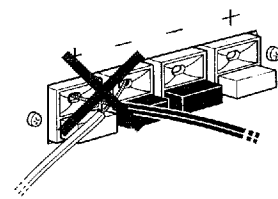

B-6 BLOCK DIAGRAM SPECIFICATIONS

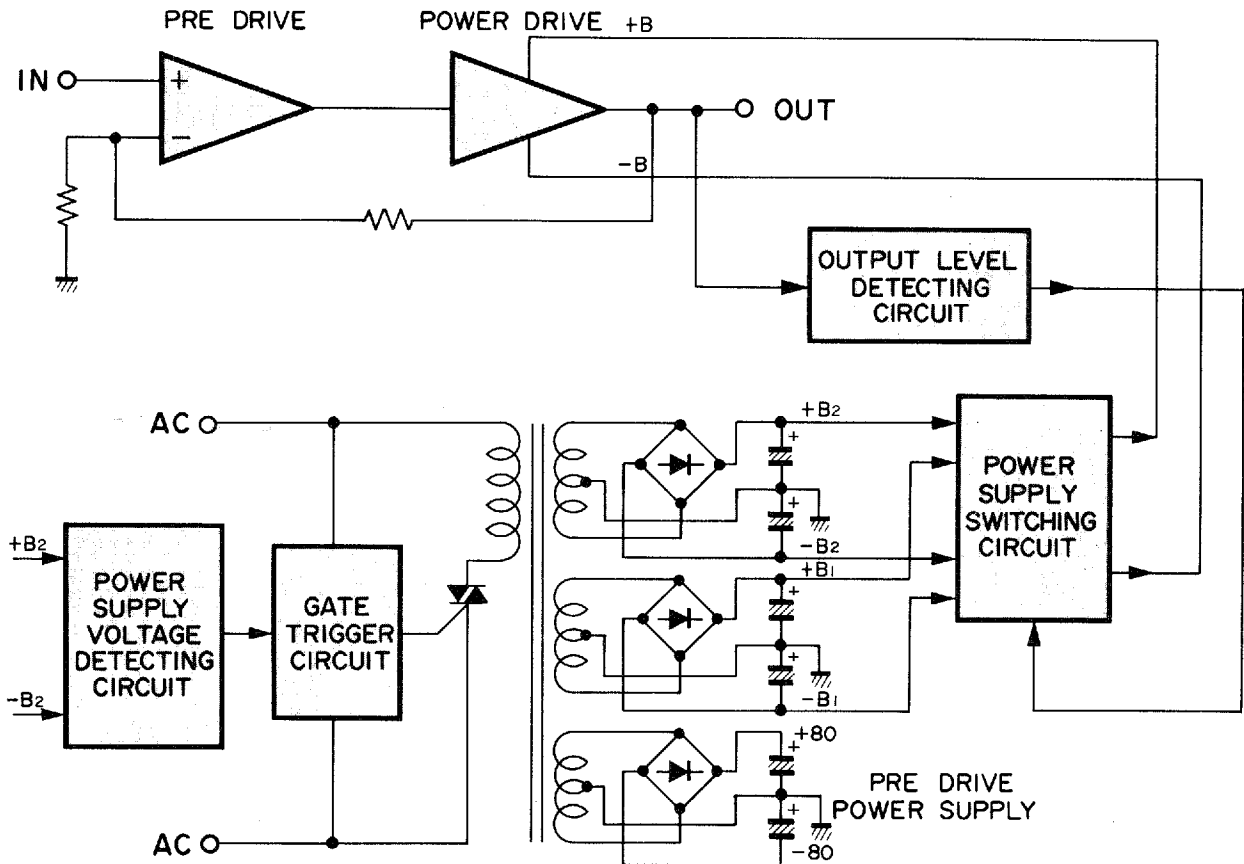

Minimum RMS Output Power	
8 ohms, 20 Hz to 20 kHz	
0.003% THD	200 W + 200 W
Total Harmonic Distortion	
8 ohms, 100 W, 20 Hz to 20 kHz	Less than 0.003%
IM Distortion Ratio (50 Hz : 7 kHz = 4 : 1)	
8 ohms, 100 W	Less than 0.003%
Power Bandwidth	
(8 ohms, 100 W, 0.03% THD)	10 Hz to 100 kHz
Damping Factor	
(8 ohms, 1 kHz)	200
Frequency Response (8 ohms)	
	DC to 100 kHz +0, -0.5 dB
Input Sensitivity/Impedance	
8 ohms, 200 W, 1 kHz	1.41 V/25 k-ohms
Signal-to-Noise Ratio (IHF A Network)	
8 ohms, input shorted	127 dB
Channel Separation (1 kHz, shorted)	
20 Hz	95 dB
1 kHz	92 dB
20 kHz	72 dB

Power Supply	
U.S.	120 V, 60 Hz
Northern Europe	220 V, 50 Hz
Power Consumption	
U.S.	200 W (1% THD, 1/10 output power)
Northern Europe	1200 W (1% THD)
Dimensions (W x H x D)	
	290 x 176.5 x 290 mm (11-7/16" x 6-15/16" x 11-7/16")
Weight	
U.S.	9.0 kg (19 lbs. 13 oz.)
Northern Europe	9.2 kg (20 lbs. 4 oz.)

B-6 TROUBLESHOOTING

Before assuming that your amplifier is faulty, check the following troubleshooting list which details the corrective action you can take yourself without having to call a service engineer. If you have any doubts or questions, get in touch with your nearest Yamaha dealer.

Fault	Cause	Cure
Power is not supplied even though the Power switch is turned on.	The power plug is not securely plugged in.	Plug it in securely.
	A fuse is blown.	Consult your Yamaha dealer.
No sound is heard from one or both speakers.	The cords from the preamplifier to the B-6 are not connected securely.	Connect them securely.
	The speaker switch is turned off.	Turn the speaker switch on.
	The balance control is rotated to the extreme left or right position on the control amplifier.	Turn the control amp's balance control to the center position.
The sound suddenly goes off.	The speaker protection circuit has activated because of DC flowing in the speaker circuit.	Turning the B-6 off and then on will reset the speaker protection circuit.
	The control amp is leaking DC into its output.	Use a control amp with no DC offset.
	Driving speakers outside the rated impedance range at high power for an extended period has activated the speaker protection circuit.	Turning the B-6 off and then on will reset the speaker protection circuit. Use speakers inside the rated 8 to 16 ohm range.
	There is a malfunction in the amplifier.	Consult your Yamaha dealer.
Unnatural bass with no ambience.	The speaker polarities are reversed.	Correct the speaker polarities.
A buzzing sound is heard from the B-6.	Sometimes vibrations are generated by the power transformer.	This does not indicate that there is any problem with the amplifier.

SINCE 1887  **YAMAHA**
NIPPON GAKKI CO., LTD. HAMAMATSU, JAPAN