

**YAMAHA**

# ***PF1500***

**ELECTRONIC PIANO  
PIANO ELECTRONIQUE  
ELECTRONIC PIANO**

**OPERATING MANUAL  
MANUEL D'UTILISATION  
BEDIENUNGSANLEITUNG**

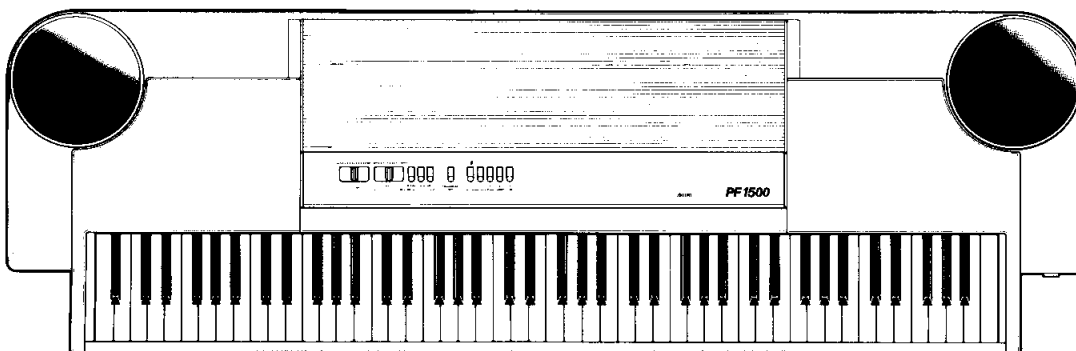

# INTRODUCTION

*Thank you for purchasing this Yamaha PF1500 Electronic Piano. This keyboard instrument incorporates the following features:*

- Yamaha's AWM (Advanced Wave Memory) tone generation system, which digitally processes the sounds of actual instruments, creating authentic timbres. The AWM system compresses data so that more data can be stored in the piano.
- Specially developed keyboard provides an action that is lighter than that of an acoustic piano, yet sensitive and natural, so the player who is used to a grand piano can switch easily to a PF1500 piano.
- Velocity sensitivity to allow expressive performance with subtle variations in tone and volume that respond to the way you play.
- Full 16-note polyphonic capacity
- A powerful internal 20W+20W amplifier, with a stereo 2-way speaker system to reproduce the sounds of an acoustic piano with full, rich, and deep tones.
- MIDI capability to allow control of and control by other MIDI instruments (refer to the MIDI OPERATION section of this manual for more information).
- The PF1500 is equipped with a digital reverberation unit with three programs, enabling performances with ambience and atmosphere. In addition, this effect may be used to modify the sounds of external devices (rhythm programmers, tone generators or synthesizers) amplified through the piano.

## PRECAUTIONS

*Your new PF1500 piano is a fine musical instrument and should be treated as such. Though it is ruggedly constructed and offers the reliability of solid-state circuitry, handle it with care and common sense. Keep the following points in mind, and your piano will give you years of reliable service.*

### • Location

Avoid exposure to direct sunlight or other sources of heat. Vibration, excessive dust, cold, low or high humidity can also cause malfunction.

### • Relocation

When moving the piano, unplug the AC power supply and all other connecting cables to prevent damage to cords and jacks.

### • Handling

Avoid rough handling. Don't drop or subject the piano to shock as this can damage the internal circuitry. Applying excessive force to terminals or controls may lead to malfunctions. Always remove plugs from sockets or other terminals by gripping them directly, not by pulling the cord.

### • AC Power Connection

The voltage requirements for your Yamaha electronic piano have been set specifically for the mains supply voltage used in your area. If you have any doubts about voltage suitability, please consult your local Yamaha dealer. If you intend to use your piano in an area with a different voltage, be sure to use an appropriate convertor.

Disconnect the piano from the AC outlet when not using it for an extended period of time. Electrical storms (lightning) can give rise to power surges, damaging digital circuitry even if the power is turned off.

### • Cleaning

Do not use abrasive cleaners, waxes, solvents or chemical dust cloths to clean the cabinet or keys of your piano, as these may dull the keys or damage the finish. Use a slightly damp cloth and a neutral cleanser.

### • Service and Modification

The piano contains no user-servicable parts. Opening it or tampering with it in any way can lead to electrical shock as well as damage and will void the product warranty. Refer all servicing to qualified YAMAHA personnel.

### • Interference through Electromagnetic Fields

Do not use your piano close to television sets, radio receivers or other equipment generating electromagnetic fields. This could cause both malfunctions of the piano's digital circuitry as well as interference noise in the other appliance.

# CONTENTS

Specifications .....	1	Transposition and Pitch Control (Tuning) .....	7
Controls and Connectors .....	2	MIDI Operation .....	8
Connections (Rear panel) .....	4	Important safety and Installation Instructions .....	11
Setting Up .....	5	MIDI Data Format .....	Add-1
Basic Operation .....	5	MIDI Implementation Chart .....	Add-5
Pedals .....	6		

## SPECIFICATIONS

- **Keyboard**  
88 keys (A-1 — C7)
- **Voices**  
PIANO 1, PIANO 2, E PIANO, HARPSICHORD, VIBE
- **Simultaneous Output Notes**  
16 notes
- **Built-in effect**  
Stereo Digital Reverb – 3 settings – ROOM, STAGE and HALL
- **Transposition Range**  
–6 to +5 semitones
- **Pitch Control Range**  
±51 cents (in 3-cent increments)
- **Pedal Controls**  
Sustain, Soft/Key Hold
- **Other Controls**  
Master Volume, TRANSPOSE/MIDI, Power Switch, Speaker On/Off, Reverb Depth
- **Jacks/Connectors**  
Phones, OUT I, OUT II, LINE IN I/MONO, LINE IN II, MIDI IN, MIDI OUT, MIDI THRU, Sustain Pedal, Soft/Key Hold Pedal
- **Main Amplifiers**  
2 x 20W
- **Speakers**  
2 x 16cm  
2 x 8cm
- **LED Indicators**  
8 — 5 x voice + 3 x Reverb  
Total of 9 : 8 panel indicators and 1 power switch indicator
- **Power Consumption**  
60W 110 — 120V (US & Canada)  
60W 220 — 240V (General Model)
- **Dimensions (W x D x H) (without stand)**  
1470 x 470 x 210 mm  
(57-7/8 x 18-1/2 x 8-1/4 inches)
- **Weight (without stand)**  
37kg (81-5/8 lb)

\* Specifications are subject to change without notice.

## SUPPLEMENTAL MARKING INFORMATION

This information on safety is provided to comply with U.S.A. laws, but should be observed by users in all countries.

Yamaha Digital Musical Instrument Products will have either a label similar to the graphic shown below or a molded/stamped facsimile of the graphic on its enclosure. The explanation of these graphics appears on this page. Please observe all cautions indicated.

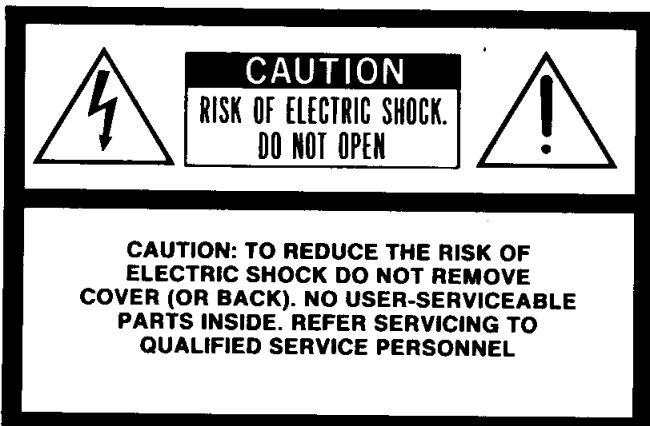

The exclamation point within an equilateral triangle is intended to alert the user to the presence of important operating and maintenance (servicing) instructions in the literature accompanying the product.



The lightning flash with arrowhead symbol, within an equilateral triangle, is intended to alert the user to the presence of uninsulated "dangerous voltage" within the product's enclosure that may be of sufficient magnitude to constitute a risk of electric shock to persons.

# CONTROLS AND CONNECTORS

## FRONT PANEL

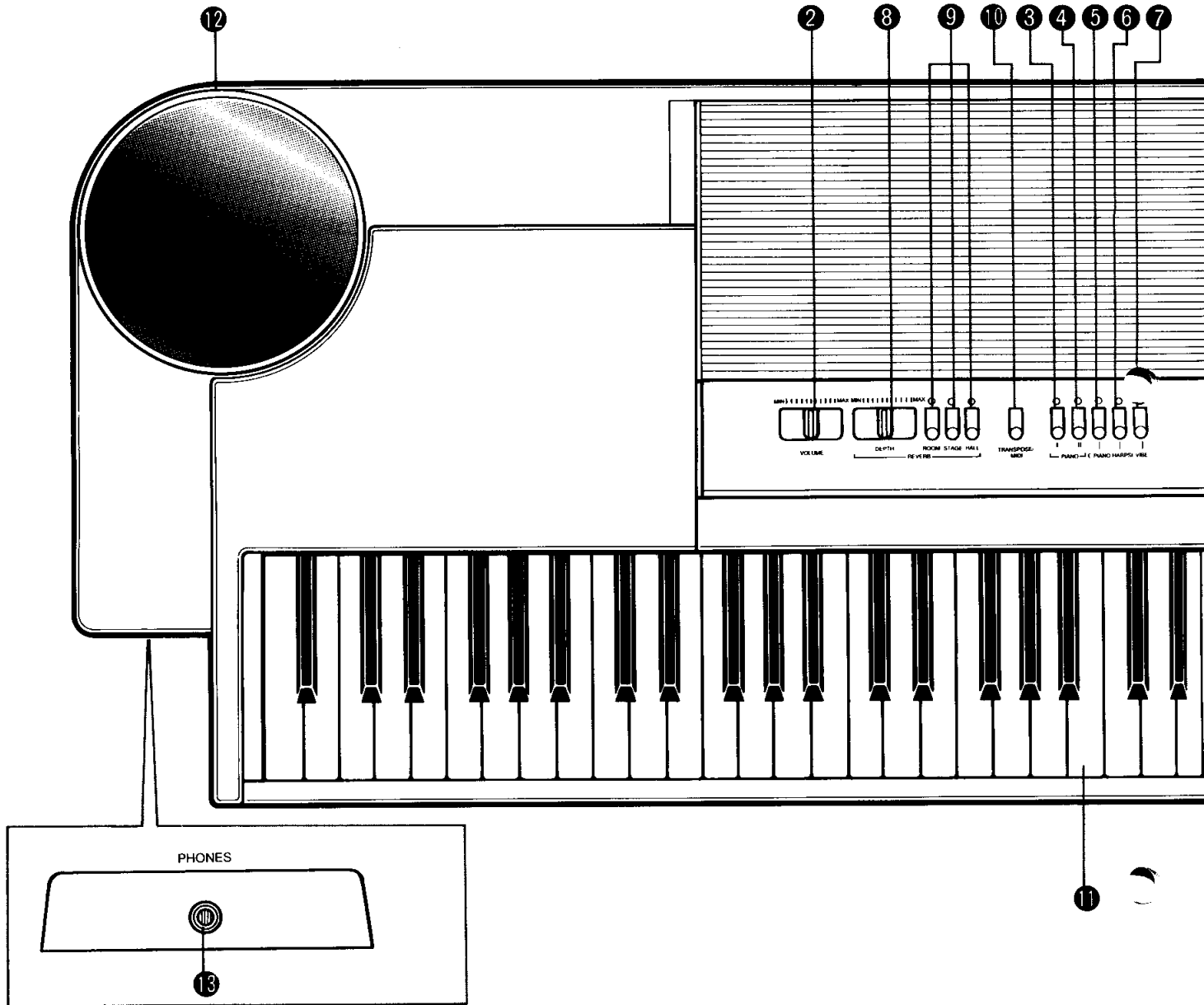

- ❶ **Power switch**  
(illuminated when on)
- ❷ **Volume control**  
Slide right to increase the volume, left to decrease the volume.
- ❸ **PIANO 1 voice select button and indicator**  
Press this button for the full sound of a concert grand piano.
- ❹ **PIANO 2 voice select button and indicator**  
Press this button for a lighter acoustic piano sound.
- ❺ **E. PIANO voice select button and indicator**  
Press this button for the sound of an electric piano.
- ❻ **HARPSICHORD voice select button and indicator**  
Press this button for the sound of a harpsichord.
- ❼ **VIBE voice select button and indicator**  
Press this button for a vibraphone (vibes) sound.
- ❽ **Reverb Depth slider**  
Pushing this slider to the left decreases the amount of reverberation applied (full left is equivalent to off), and pushing it to the right increases the amount of reverberation.

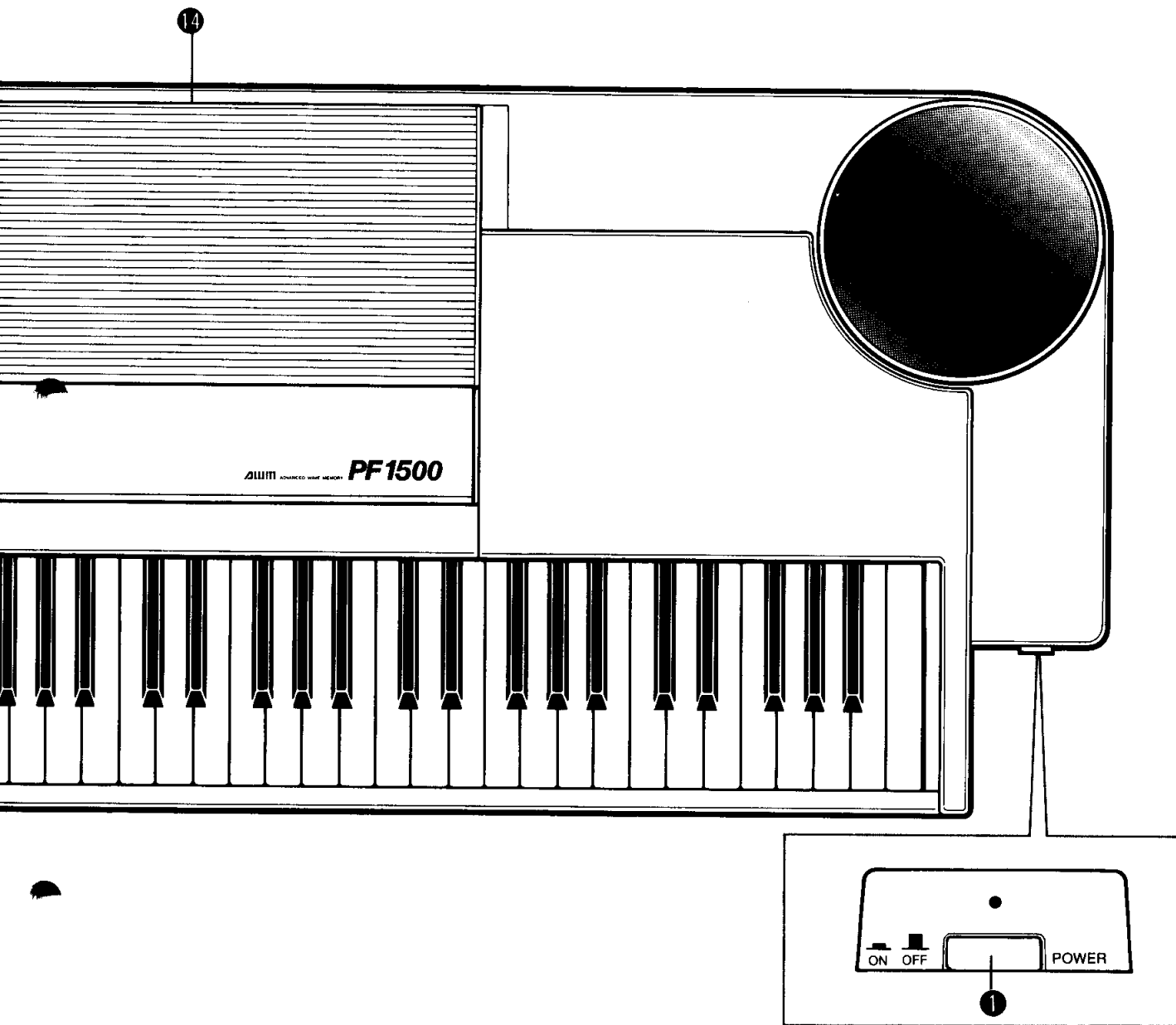

**9 Reverb select buttons and indicators:  
HALL, STAGE and ROOM**

The PF1500's digital reverb can simulate the reverberation types associated with these three environments. Press one of these switches to pick the one which suits your musical mood.

**10 TRANSPOSE/MIDI button**

This has many functions in conjunction with other buttons, which are described later in this manual

**11 88-key keyboard**

**12 8cm speakers**

Do not put sheet music, etc over the speakers when using the piano's internal amplifier and speakers, otherwise the sound will be muffled.

**13 Headphone socket**

Insert headphones here for private practice. Note that the speakers will be automatically be turned off when the headphones are inserted.

**14 Music stand**

Pull towards you and lift, as described in the **SETTING UP** section.

## CONNECTIONS (REAR PANEL)

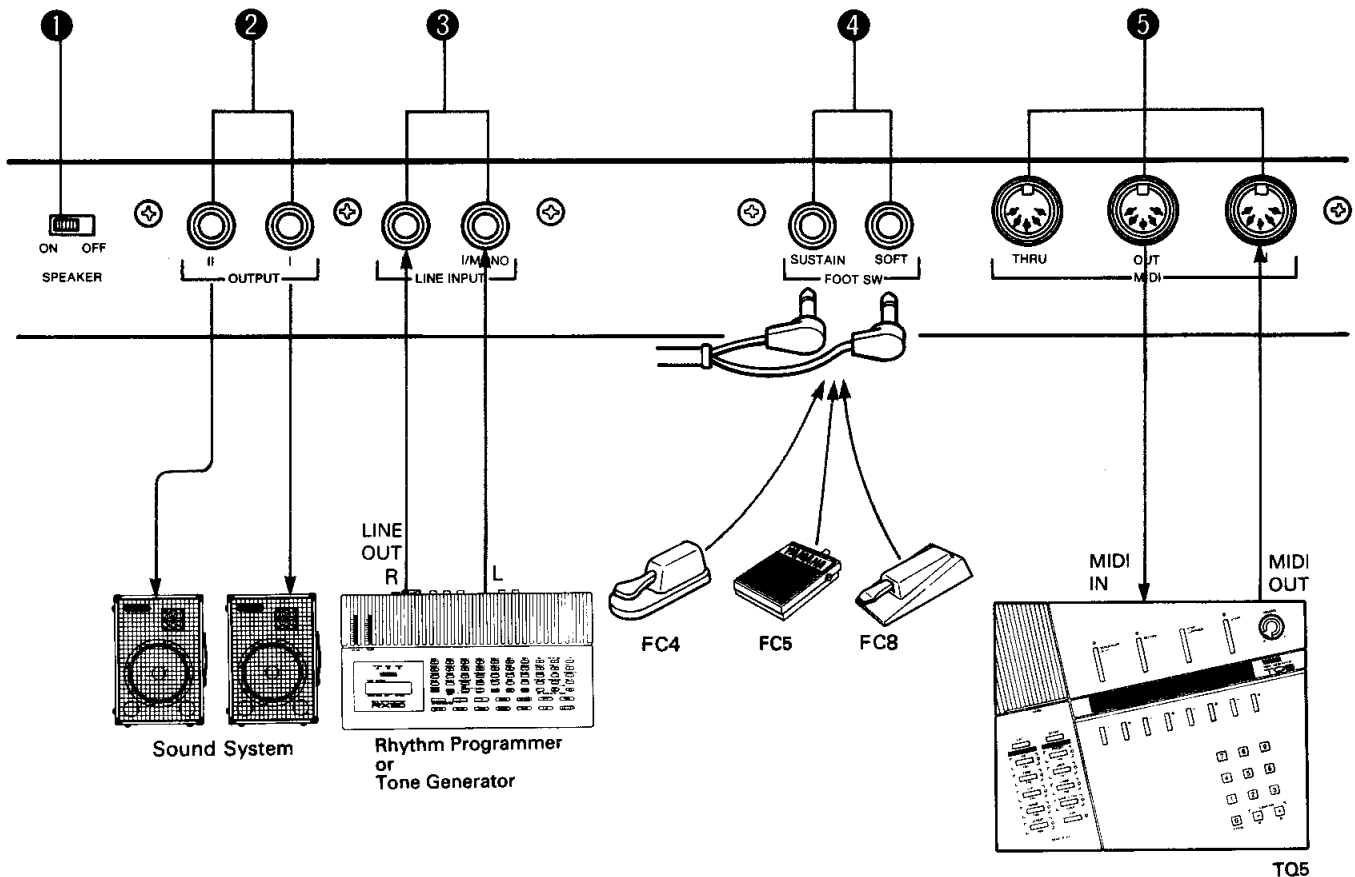

### 1 Speaker ON/OFF switch

This switch turns the sound from the PF1500's speakers on and off.

### 2 OUTPUT terminals (I and II)

These jack terminals can be used to connect the PF1500 to an external amplifier, mixer, etc. A stereo signal is output when the reverb is used.

### 3 LINE INPUT terminals (I/MONO and II)

These jack terminals can be used to connect other equipment (eg RX rhythm programmer, TQ5 tone generator) to be played through the PF1500's amplifier and speakers. **DO NOT** use these sockets to connect speaker-level signals. Damage will occur to the PF1500, and possibly to the other equipment.

### 4 SUSTAIN and SOFT pedal connections

Use these sockets to connect the PF1500 stand pedals, as described in the section **SETTING UP**.

\* Effects can also be turned on and off using the optional foot pedals FC4, FC5, or FC8. (The half-pedal effect is not accessible with the FC8.)

### 5 MIDI THRU, OUT and IN terminals

MIDI (Musical Instrument Digital Interface) allows the PF1500 to transmit and receive musical commands to and from other MIDI-equipped devices. The IN terminal should be used if the PF1500 is to be controlled by a sequencer (eg TQ5) or another keyboard, and the OUT terminal for when the PF1500 is to control another device (eg the tone generators of the TQ5). The THRU terminal echoes the data received at the IN terminal, and is used when "daisy-chaining" MIDI devices. See the section on **MIDI OPERATION** for full details.

# SETTING UP

The PF1500 has a second set of speakers located on the underside of the keyboard. Before playing, attach the stand, referring to the separate Assembly Instructions sheet.

When the keyboard has been placed on the stand, continue with the following procedure for playing.

1. Plug the AC power cord into an AC outlet.
2. Though the PF1500 has its own internal amplifier/speaker system, you can also play it through an external sound system via the LINE OUT (I, II) sockets. The piano's output is normally mono, but when the reverb is used, a stereo signal is output. The SPEAKER switch on the back panel may be used to turn the internal speakers on and off.
3. For headphone listening, connect a pair of headphones to the PHONES socket. When headphones are inserted, the internal speakers are automatically turned off.
4. To control the piano from an external MIDI device, connect the MIDI OUT of the MIDI device to the MIDI IN of the piano. To control an external MIDI device from the piano, connect the MIDI IN of the MIDI device to the MIDI OUT of the piano. (Refer to the MIDI OPERATION section for further details.)
5. The LINE IN sockets can be used for connecting a tape recorder, synthesizer, drum machine, etc, which can be listened to through the piano's own internal amplifier and speakers while you play. The OUTPUT connectors of the external source should be connected to the LINE IN sockets on the piano. The level should be adjusted at the external source.

## NOTE:

Never feed speaker-level signals to the piano's LINE IN sockets - it could cause damage to the piano's internal circuitry.

6. Set the music stand in position by pushing it about 5cm (2") away from the keyboard, and then lifting it back. The exact position may then be adjusted forwards or backwards.

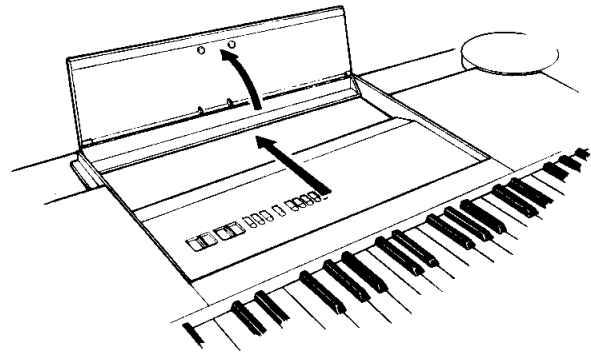

# BASIC OPERATION

## POWER

Turn on the power switch. If the piano is to be connected to other amplification or MIDI instruments, do not turn on the power until all connections have been made.

## VOICE SELECT

Select the desired voice by pressing a voice select button on the front panel. There are five voices: PIANO 1, PIANO 2, E PIANO, HARPSICHORD and VIBE. When a voice has been selected, the corresponding LED above the select switch will light.

## VOLUME

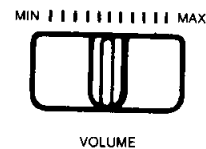

Adjust the volume using the Volume slider on the front panel (pushing it to the right increases the volume, and pushing it to the left decreases the volume).

## REVERB

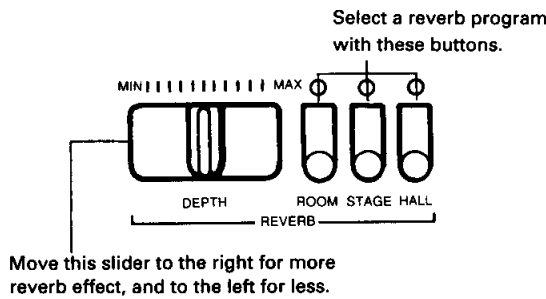

There are three reverberation settings which may be selected: ROOM, STAGE and HALL. ROOM simulates the reverberations to be found in a normal sized room. STAGE simulates the reverberation characteristics of a stage, and HALL provides a larger, more spacious feeling than ROOM. Once the selection of reverberation type has been made, the corresponding LED will light up. The amount of reverberation affecting the piano sound can be adjusted by means of the Depth slider (pushing it right adds more reverberation, and pushing it to the left decreases the effect). Note that any external sound sources connected to the LINE IN sockets on the PF1500 will also be affected by the reverberation settings.

## PEDALS

*The two pedals on the stand of the PF1500 may be used to create sustain and soft (una corda) or key hold (sostenuto) effects as on an acoustic piano.*

### USE OF THE SUSTAIN PEDAL

Press the sustain pedal (the right-hand pedal) to sustain all notes played, up to the 16-note polyphonic limit. Further notes played will cancel the first notes played, in the order in which they were played.

### SELECTION OF SOFT/ KEY HOLD PEDAL FUNCTIONS

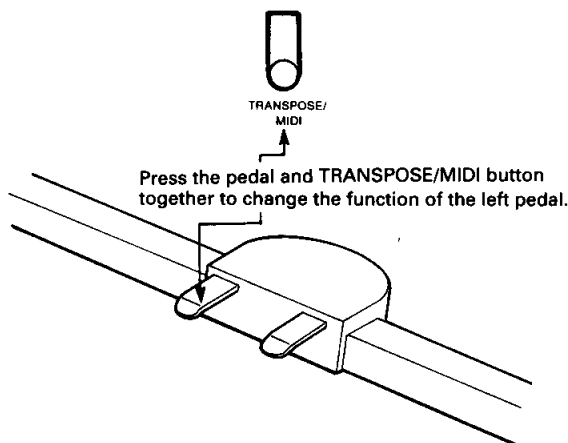

The left-hand pedal may be used as either a soft (una corda) or Key Hold (Sostenuto) pedal. To switch between these two pedal functions, hold down the TRANSPOSE/MIDI button and depress the left-hand pedal. To change the function, repeat the above procedure.

#### NOTE:

When the power to the piano is turned on, the soft key function is automatically selected.

### USE OF THE SOFT PEDAL

Pressing the pedal when the Soft pedal function is selected mutes the sound of the piano (una corda).

### USE OF THE KEY HOLD PEDAL

Pressing the pedal when the Key Hold function is selected causes only the notes which are currently held down to be selected. Subsequent notes played while the pedal is depressed are not sustained (sostenuto).



# TRANSPOSITION AND PITCH CONTROL (TUNING)

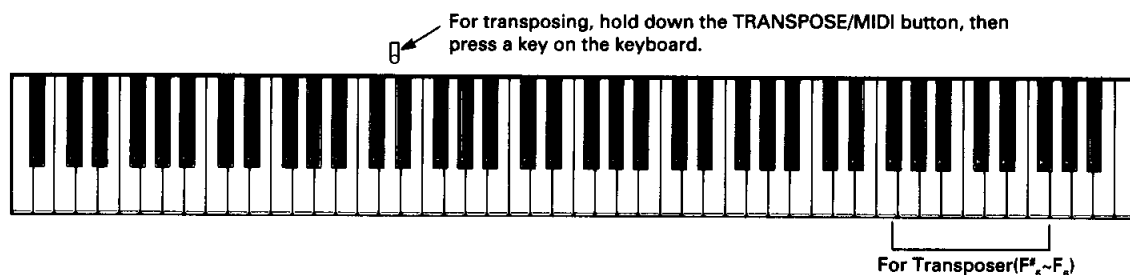
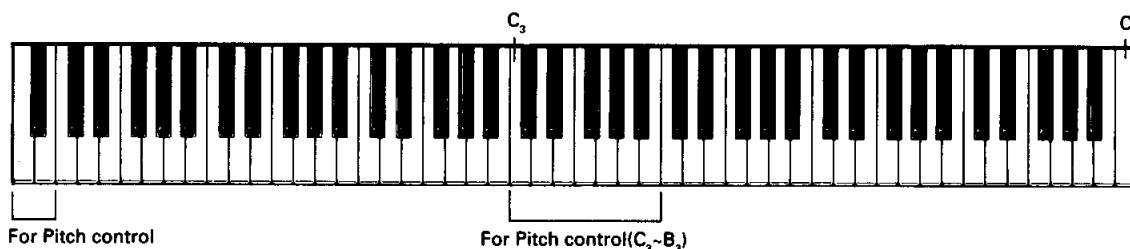

## TRANSPOSITION

This feature allows you to change the key of the entire instrument in half-step (semitone) intervals.

To change the transposition setting, hold down the TRANSPOSE/MIDI button and press one of the keys between F#5 and F6. The piano will then be transposed by an interval corresponding to the interval between C6 and the key pressed.

**NOTE:**

The normal playing key (Middle C=C3) is automatically selected when the power is turned on.

## PITCH CONTROL

This feature allows you to make fine adjustments to the pitch of the entire instrument in about 3-cent steps (1 cent equals 1/100th of a semitone). This allows you to match the tuning of the piano to that of accompanying instruments or tapes.

To raise the pitch, simultaneously hold down the two lowest white keys and press any key between C3 (Middle C) and B3 (the B above Middle C). Each press of the key raises the pitch by three cents.

To lower the pitch, execute the same procedure while holding down the lowest white key and lowest black key. Tuning can be adjusted up to a maximum of  $\pm 51$  cents. Thus, when used in combination with the Transposition function, the piano can be set to any pitch within a one-octave range.

**NOTE:**

Concert pitch (A3=440Hz) is automatically selected when the piano is first turned on.

# MIDI OPERATION

The MIDI (Musical Instrument Digital Interface) connections on the piano allow you to connect it to other MIDI keyboards, tone generator modules, samplers, sequencers, drum machines, computers and other signal processors. This enables the piano to play or be played by other synthesizers and execute many other MIDI performance functions. MIDI data is transmitted on any of up to 16 MIDI channels. Normally, MIDI devices connected together should be set to the same MIDI channel number.

The piano can transmit and receive the following MIDI data:

- Key On/Key Off (indicate that a note has been pressed and released, respectively).
- Note Number (indicates which note has been pressed).
- Velocity (indicates the speed or force with which a key was pressed).
- Foot Pedal Functions (also known as control changes).

- Program Changes (Programs 1 through 5 can be selected on an external MIDI instrument using the piano's Voice Select buttons, or the piano's voices can be selected from an external MIDI device. The program numbers for the piano's voices are as follows: 1 = PIANO 1, 2 = PIANO 2, 3 = E PIANO, 4 = HARPSICHORD, 5 = VIBE).

Refer to the MIDI section and MIDI Implementation Chart at the end of this manual for further information.

## SETTING MIDI FUNCTIONS

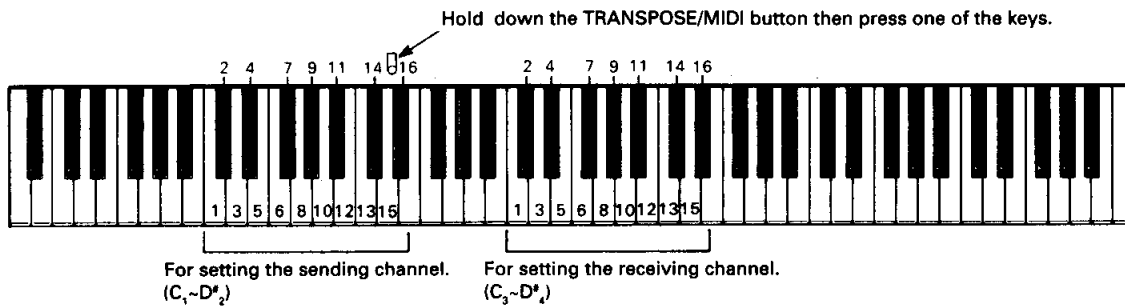

### 1. MIDI TRANSMIT CHANNEL SELECT

MIDI data can be sent on any of up to 16 MIDI channels. The piano's MIDI Transmit channel (sending channel) should match the MIDI Receive channel of the MIDI device that it is controlling.

Hold down the MIDI/TRANSPOSE button, then press one of the keys between C1 and D#2 to select the MIDI Transmit channel number.

**NOTE:**

When the piano's power is turned on, the MIDI Transmit channel is automatically set to 1.

### 2. OMNI ON/OFF, MIDI RECEIVE CHANNEL SELECT

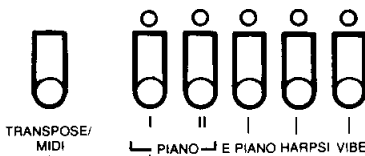

Press these two buttons together to set OMNI on or off.

MIDI data may be received on any of 16 MIDI channels. The piano's MIDI Receive mode may be set to Omni On (in which case, MIDI data received on any or all of the MIDI channels will be recognized) or to Omni Off (in which case, MIDI data is received only on the single selected MIDI channel, which should match the MIDI Transmit channel of the controlling device).

Hold down the TRANSPOSE/MIDI button, then press the PIANO 1 Voice Select button to switch between Omni On and Omni Off. When the PIANO 1 LED is lit, the Omni mode is turned off. To select the MIDI Receive channel, hold down the TRANSPOSE/MIDI button and press one of the keys between C3 and D#4 (as shown in the diagram at the start of the SETTING MIDI FUNCTIONS section).

**NOTE:**

When the piano's power is turned on, the MIDI Receive channel is automatically set to 1, and the OMNI mode is set to ON.

### 3. LOCAL ON/OFF FUNCTION

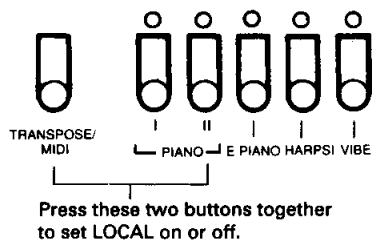

The Local On/Off function allows you to select whether or not the piano's own internal voices will be played by its keyboard. In normal use, this function will be set to ON. However, if you wish to use the piano only as a MIDI controller keyboard (for example to play a synthesizer or a tone generator module), you can turn off the Local function, effectively isolating the piano's internal voices from its keyboard, so that only the external MIDI device will produce sound when you play the piano keyboard. Using the Local Off function, you could also use another external MIDI device (such as a sequencer) to play the piano's internal voices. Hold down the TRANSCOPE/MIDI button, then press the PIANO 2 voice select button to switch between Local On and Local Off. When the PIANO 2 LED is lit, the Local function is turned off.

#### NOTE:

When the piano's power is turned on, the Local function is automatically set to Local On.

### 4. PROGRAM CHANGE CANCEL

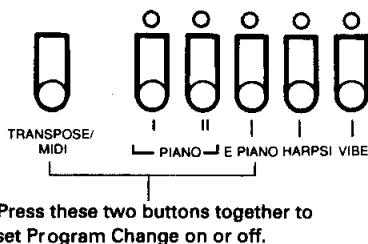

When controlling a MIDI device from the piano, the external MIDI device's programs can be selected by pressing Voice Select buttons on the piano. Also, when the piano is controlled from another MIDI device, the piano's voices can be selected from the external MIDI device. For both transmission and reception, the piano's Voice Select buttons correspond to Programs 1 through 5.

You can have independent program change ability by cancelling the piano's ability to receive and transmit program changes. This is done by turning off the piano's Program Change function.

Hold down the TRANSCOPE/MIDI button, then press the E PIANO Voice Select button, to switch between Program Change On and Program Change Off. When the E PIANO LED is lit, the Program Change function is turned on.

#### NOTE:

When the piano's power is turned on, the Program Change function is automatically set to Program Change On.

### 5. CONTROL CHANGE CANCEL

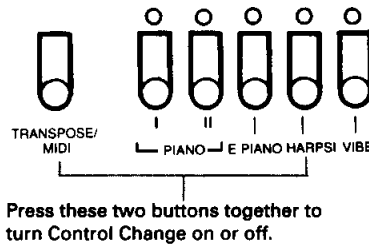

When controlling a MIDI device from the piano, the external MIDI device will be affected by the piano's foot pedals (sustain and soft/key hold). Also, when controlling the piano from an external MIDI device, the piano will respond to the external device's foot pedals. You may wish to have independent foot pedal capability by cancelling the piano's ability to receive and transmit foot pedal data. This is done by turning off the piano's Control Change function.

Hold down the TRANSCOPE/MIDI button, then press the HARPSICHORD Voice Select button to switch between Control Change On and Control Change Off. When the HARPSICHORD LED is lit, the Control Change function is turned on.

#### NOTE:

When the piano's power is turned on, the Control Change function is automatically turned to Control Change On.

## MIDI APPLICATIONS

### 1. BASIC MIDI SYSTEM

(PIANO plus YS100 SYNTHESIZER)

In this example, the piano is used to play the Yamaha YS100 Digital Synthesizer, allowing you to add rich orchestral or instrumental voices or exciting synth-type voices to the sound of your piano. Connect the MIDI OUT of your piano to the MIDI IN of your YS100. The YS100 will respond to your playing as sensitively as does the piano, and you can select whether or not the YS100 responds to the piano's foot pedals. A volume pedal may be used to independently control the YS100's volume, which may be listened to through the piano's internal speakers (using the LINE IN audio connections on the piano).

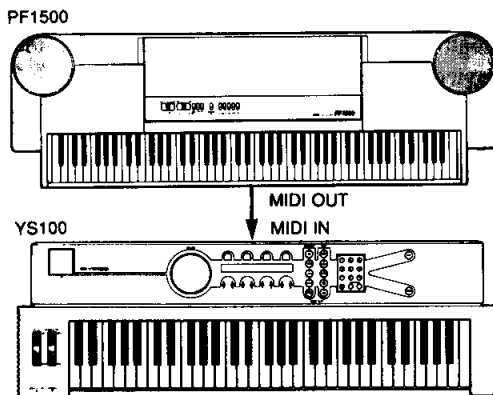

### 2. EXPANDED SYNTH SYSTEM

(PIANO plus TQ5 plus RX8)

This system, using the TQ5 tone generator/sequencer, allows you not only to add other voices and percussion accompaniments to the piano's voice, but to record and play back multi-part music on the TQ5 Digital Tone Generator/Sequencer, which controls its own and the piano's voices as well as synchronizing the RX8. The piano's Omni function should be turned off, to avoid receiving data on unwanted MIDI channels. The RX8 can be programmed to add full rhythm and percussion parts to songs, kept in perfect time by the TQ5's sequencer section.

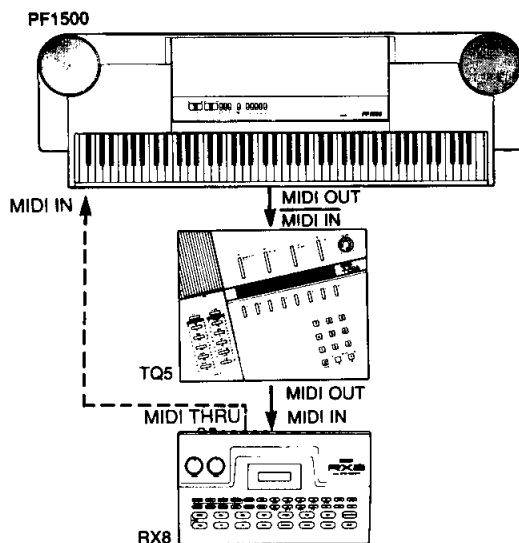

### 3. FULL MIDI SEQUENCER SYSTEM

(PIANO, QX5FD, TX81Z and RX8)

Using this high-potential MIDI system, full professional-quality musical performances can be created, stored on diskette and replayed using the QX5FD to control all the other components of the system. Different parts can be recorded on separate tracks of the QX5FD, and replayed on different MIDI channels for full multi-timbral polyphonic performances. In addition, with the QX5FD, transposition, tempo changes within pieces, and full editing functions on recorded performances are all possible. The TX81Z can be played from the piano keyboard to give combinations of up to eight sounds simultaneously with 8-note polyphony, so the resources of a full digital orchestra and/or synth effects are at your fingertips. To round off the system, the incredibly versatile and realistic RX8 rhythm programmer is used to add sparkling drums and percussion to the music.

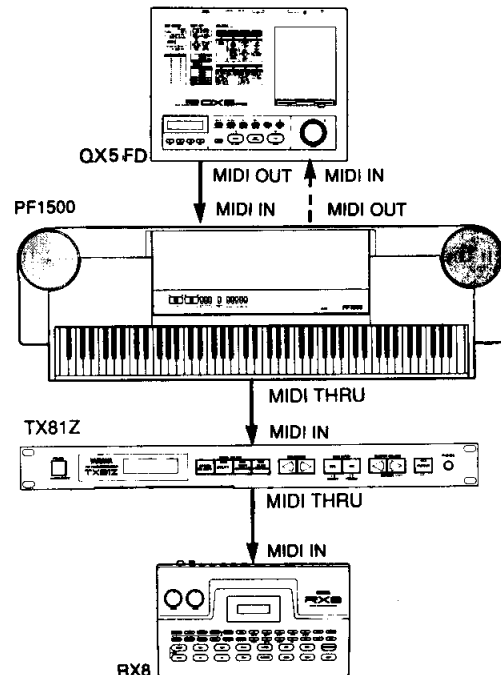

# IMPORTANT SAFETY AND INSTALLATION INSTRUCTIONS

INFORMATION RELATING TO POSSIBLE PERSONAL INJURY, ELECTRIC SHOCK AND  
FIRE HAZARD POSSIBILITIES HAS BEEN INCLUDED IN THIS LIST.

**WARNING** — When using electronic products, basic precautions should always be followed, including the following:

1. Read all Safety and Installation Instructions, Supplemental Marking and Special Message Section data, and any applicable assembly instructions BEFORE using this product.
2. Check unit weight specifications BEFORE you attempt to move this product.
3. Main power supply verification. Yamaha Digital Musical Instrument products are manufactured specifically for use with the main supply voltage used in the area where they are to be sold. The main supply voltage required by those products is printed on the name plate. If any doubt exists please contact the nearest Yamaha Digital Musical Instrument retailer.
4. Some Yamaha Digital Musical Instrument products utilize external power supplies or adapters. Do NOT connect products of this type to any power supply or adapter other than the type described in the owners manual or as marked on the unit.
5. This product may be equipped with a plug having three prongs or a polarized line plug (one blade wider than the other). If you are unable to insert the plug into the outlet, contact an electrician to have the obsolete outlet replaced. Do NOT defeat the safety purpose of the plug. Yamaha products not having three prong or polarized line plugs incorporate construction methods and designs that do not require line plug polarization.
6. **WARNING** — Do NOT place objects on the power cord or place the unit in a position where anyone could walk on, trip over, or roll anything over cords of any kind. An improper installation of this type can create the possibility of a fire hazard and/or personal injury.
7. Environment: Your Yamaha Digital Musical Instrument should be installed away from heat sources such as heat registers and/or other products that produce heat.
8. Ventilation: This product should be installed or positioned in a way that its placement or location does not interfere with proper ventilation.
9. Yamaha Digital Musical Instrument products are frequently incorporated into "Systems" which are assembled on carts, stands or in racks. Utilize only those carts, stands, or racks that have been designed for this purpose and observe all safety precautions supplied with the products. Pay special attention to cautions that relate to proper assembly, heavier units being mounted at the lower levels, load limits, moving instructions, maximum usable height and ventilation.
10. Yamaha Digital Musical Instrument products, either alone or in combination with amplification, headphones, or speakers, may be capable of producing sound levels that could cause permanent hearing loss. Do NOT operate at high volume levels or at a level that is uncomfortable. If you experience any discomfort, ringing in the ears, or suspect any hearing loss, you should consult an audiologist.
11. Do NOT use this product near water or in wet environments. For example, near a swimming pool, spa, in the rain, or in a wet basement.
12. Care should be taken so that objects do not fall, and liquids are not spilled into the enclosure.
13. Yamaha Digital Musical Instrument products should be serviced by a qualified service person when:
  - a. The power supply/power adapter cord or plug has been damaged; or
  - b. Objects have fallen, or liquid has been spilled into the products; or
  - c. The unit has been exposed to rain; or
  - d. The product does not operate, exhibits a marked change in performance; or
  - e. The product has been dropped, or the enclosure of the product has been damaged.
14. When not in use, always turn your Yamaha Digital Musical Instrument equipment "OFF". The power supply cord should be unplugged from the outlet when the equipment is to be left unused for a long period of time. NOTE: In this case, some units may lose some user programmed data. Factory programmed memories will not be affected.
15. Electromagnetic Interference (RFI). Yamaha Digital Musical Instruments utilize digital (high frequency pulse) technology that may adversely affect Radio/TV reception. Please read FCC Information (next page) for additional information.
16. Do NOT attempt to service this product beyond that described in the user maintenance section of the owners manual. All other servicing should be referred to qualified service personnel.

**PLEASE KEEP THIS MANUAL  
FOR FUTURE REFERENCE!**

This information on safety is provided to comply with U.S.A. laws, but should be observed by users in all countries.

# SPECIAL MESSAGE SECTION

**ELECTROMAGNETIC INTERFERENCE (RFI):** Your Yamaha Digital Musical Instrument Product has been type tested and found to comply with all applicable regulations. However, if it is installed in the immediate proximity of other electronic devices, some form of interference may occur. For additional RFI information see the FCC information section located in this manual.

**IMPORTANT NOTICE:** This product has been tested and approved by independent safety testing laboratories in order that you may be sure that when it is properly installed and used in its normal and customary manner, all foreseeable risks have been eliminated. **DO NOT** modify this unit or commission others to do so unless specifically authorized by Yamaha. Product performance and/or safety standards may be diminished. Claims filed under the expressed warranty may be denied if the unit is/has been modified. Implied warranties may also be affected.

**SPECIFICATIONS SUBJECT TO CHANGE:** The information contained in this manual is believed to be correct at the time of printing. Yamaha reserves the right to change or modify specifications at any time without notice or obligation to update existing units.

**NOTICE:** Service charges incurred due to a lack of knowledge relating to how a function or effect works (when the unit is operating as designed), are not covered by the manufacturer's warranty. Please study this manual carefully before requesting service.

**STATIC ELECTRICITY CAUTION:** Some Yamaha Digital Musical Instrument products have modules that plug into the unit to perform various functions. The contents of a plug-in module can be altered/damaged by static electricity discharges. Static electricity build-ups are more likely to occur during cold winter months (or in areas with very dry climates) when the natural humidity is low. To avoid possible damage to the plug-in module, touch any metal object ( a metal desk lamp, a door knob, etc.) before handling the module. If static electricity is a problem in your area, you may want to have your carpet treated with a substance that reduces static electricity build-up. See your local carpet retailer for professional advice that relates to your specific situation.

Model \_\_\_\_\_

Serial No. \_\_\_\_\_

Purchase Date \_\_\_\_\_

## FCC INFORMATION

While the following statements are provided to comply with FCC Regulations in the United States, the corrective measures listed below are applicable worldwide.

This series of Yamaha professional music equipment uses frequencies that appear in the radio frequency range and if installed in the immediate proximity of some types of audio or video devices (within three meters), interference may occur. This series of Yamaha professional music equipment has been type tested and found to comply with the specifications set for a class B computing device in accordance with those specifications listed in subpart J of part 15 of the FCC rules. These rules are designed to provide a reasonable measure of protection against such interference. However, this does not guarantee that interference will not occur. If your professional music equipment should be suspected of causing interference with other electronic devices, verification can be made by turning your professional music equipment off and on. If the interference continues when your equipment is off, the equipment is not the source of interference. If your equipment does appear to be the source of the interference, you should try to correct the situation by using one or more of the following measures:

Relocate either the equipment or the electronic device that is being affected by the interference. Utilize power outlets for the professional music equipment and the device being affected that are on different branch (circuit breaker or fuse) circuits, or install AC line filters.

In the case of radio or TV interference, relocate the antenna or, if the antenna lead-in is 300 ohm ribbon lead, change the lead-in to a co-axial type cable.

If these corrective measures do not produce satisfactory results, please contact your authorized Yamaha professional products dealer for suggestions and/or corrective measures.

If you cannot locate a franchised Yamaha professional products dealer in your general area contact the Electronic Service Department, Yamaha Corporation of America, 6600 Orangethorpe Ave., Buena Park, CA 90620, U.S.A.

If for any reason, you should need additional information relating to radio or TV interference, you may find a booklet prepared by the Federal Communications Commission helpful:

"How to Identify and Resolve Radio — TV Interference Problems". This booklet is available from the U.S. Government Printing Office, Washington D.C. 20402 — Stock No. 004-000-00345-4.

**This information on safety is provided to comply with U.S.A. laws, but should be observed by users in all countries.**

### **IMPORTANT NOTICE FOR THE UNITED KINGDOM**

#### **Connecting the Plug and Cord**

**IMPORTANT.** The wires in this mains lead are coloured in accordance with the following code:

**BLUE : NEUTRAL**

**BROWN : LIVE**

As the colours of the wires in the mains lead of this apparatus may not correspond with the coloured markings identifying the terminals in your plug proceed as follows:

The wire which is coloured **BLUE** must be connected to the terminal which is marked with the letter **N** or coloured **BLACK**.

The wire which is coloured **BROWN** must be connected to the terminal which is marked with the letter **L** or coloured **RED**.

# MIDI DATA FORMAT

## 1. Transmission Conditions

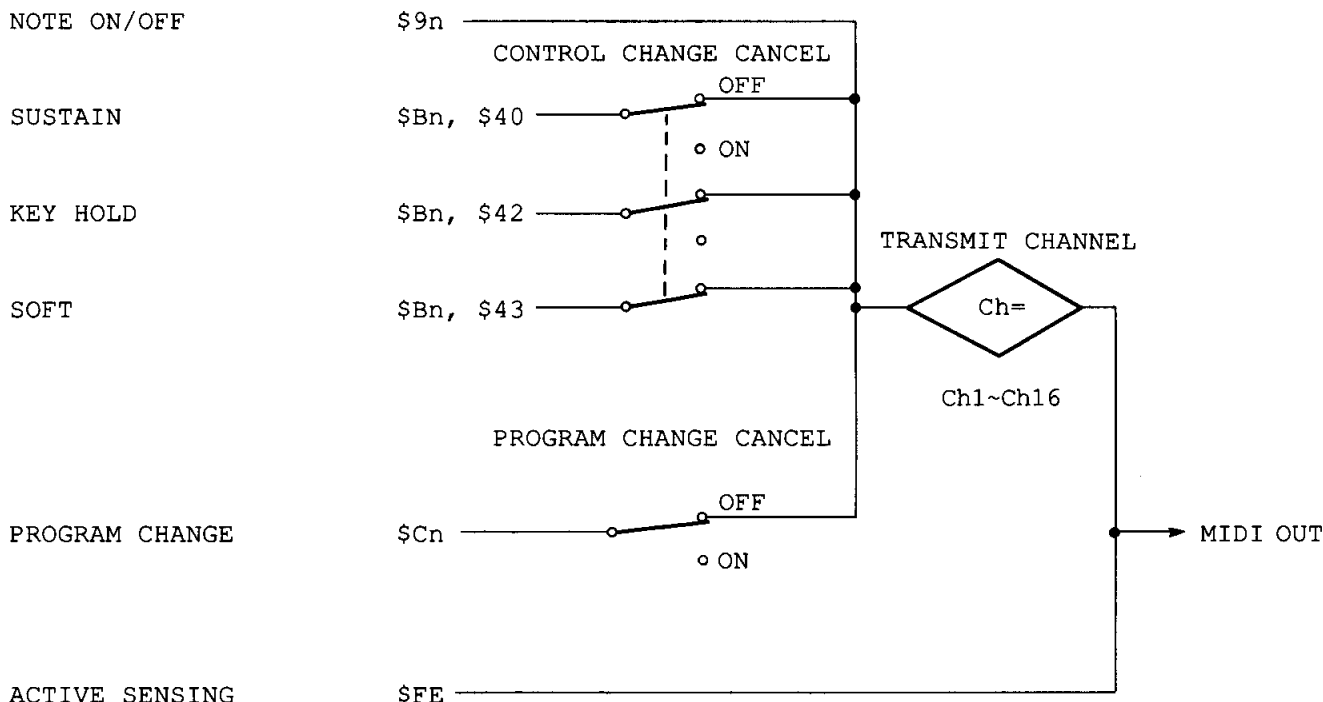

## 2. Transmission Data

Messages other than Active Sensing messages can be transmitted on the specified MIDI transmission channel. Received messages are output without modification from the MIDI THRU terminal.

### 2-1. Channel Information

#### 1) Channel Voice Message

##### ① Key On/Off

Sent when a key is pressed or released.

Status: 1001nnnn (9nH) n=0 (channel number 1) - 15 (channel number 16)  
 Note No.: 0kkkkkkk k=21 (A-1) - 108 (C7)  
 Velocity: 0vvvvvvv v=0 - 127 (1 - 127: Key On; 0: Key Off)

##### ② Control Change

Sent when the foot pedal is pressed or released. Three kinds of messages can be sent. However, the Control Change Cancel must be OFF.

Status: 1011nnnn (BnH) n=0 (channel number 1) - 15 (channel number 16)  
 Control No.: 0ccccccc  
 Control Value: 0vvvvvvv

Control No.	Control Value
c=64 SUSTAIN	v=0 (OFF), 127 (ON)
c=66 KEY HOLD	v=0 (OFF), 127 (ON)
c=67 SOFT	v=0 (OFF), 127 (ON)



③ Program Change

Sent when the voice has been changed, or when a Program Change Dump Request has been received. However, the Program Change Cancel must be OFF.

Status: 1100nnnn (CnH) n=0 (channel number 1) - 15 (channel number 16)  
 Program No.: 0ppppppp p=0 (PIANO I)  
 1 (PIANO II)  
 2 (E PIANO)  
 3 (HARPSI)  
 4 (VIBE)

2-2. System Information

1) System Realtime Message

① Active Sensing

Transmitted once every approximately 200msec.

Status: 11111110 (FEH)

3. Reception Conditions

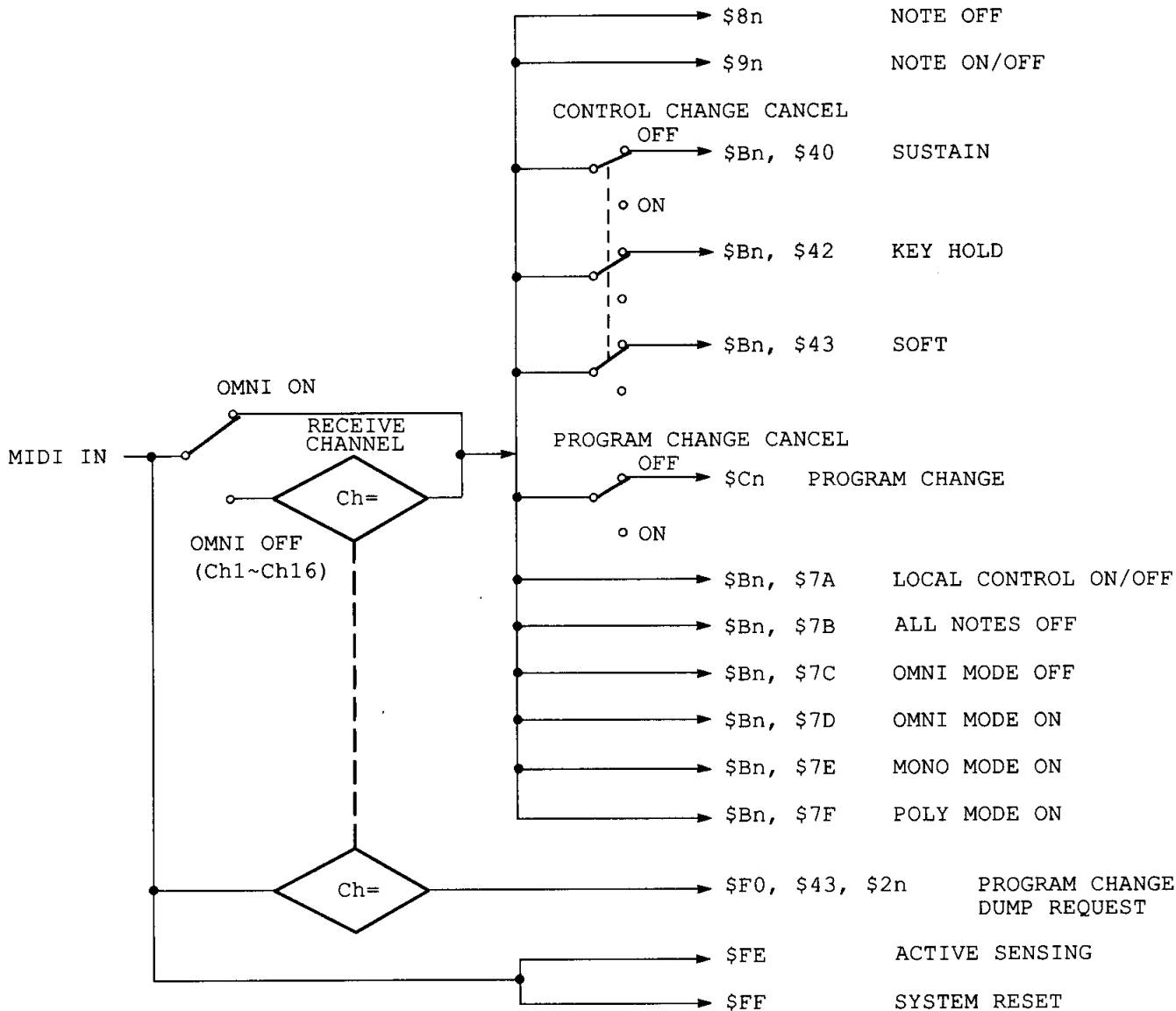

## 4. Reception Data

Messages other than Active Sensing or System Reset messages can be received on the specified MIDI reception channel. Received messages are output without modification through the MIDI THRU terminal.

### 4-1. Channel Information

#### 1) Channel Voice Message

##### ① Key Off

Corresponds to an instrument which transmits Note Off with 8nH.

Status: 1000nnnn (8nH) n=0 (channel number 1) - 15 (channel number 16)  
Note No.: 0kkkkkkk k=21 (A-1) - 108 (C7)  
Velocity: 0vvvvvvv v:ignored

##### ② Key On/Off

The sounded pitch changes depending on the note number, while the volume and voice change depending on the velocity.

Status: 1000nnnn (9nH) n=0 (channel number 1) - 15 (channel number 16)  
Note No.: 0kkkkkkk k=21 (A-1) - 108 (C7)  
Velocity: 0vvvvvvv v=0 - 127 (1 - 127: Key On; 0: Key Off)

##### ③ Control Change

Three kinds of messages can be sent. However, the Control Change Cancel must be OFF.

Status: 1011nnnn (BnH) n=0 (channel number 1) - 15 (channel number 16)  
Control No.: 0ccccccc  
Control Value: 0vvvvvvv

Control No.	Control Value
c=64 SUSTAIN	v=0 (OFF), 127 (ON)
c=66 KEY HOLD	v=0 (OFF), 127 (ON)
c=67 SOFT	v=0 (OFF), 127 (ON)

##### ④ Program Change

Voice is determined by program number.

Status: 1100nnnn (CnH) n=0 (channel number 1) - 15 (channel number 16)  
Program No.: 0ppppppp p=0 (PIANO I)  
1 (PIANO II)  
2 (E PIANO)  
3 (HARPSI)  
4 (VIBE)  
5 - 127 (ignored)

Status: 1011nnnn (BnH) n=0 (channel number 1) - 15 (channel number 16)  
 Control No.: 0ccccccc  
 Control Value: 0vvvvvvv

Control No.	Control Value
c=122 LOCAL CONTROL ON/OFF (upon reception, local control setting goes ON or OFF)	V=0 (OFF), 127 (ON)
c=123 ALL NOTE OFF (upon reception, all keys are considered to have been released)	V=0
c=124 OMNI OFF (upon reception, OMNI goes OFF)	V=0
c=125 OMNI ON (upon reception, OMNI goes ON)	V=0
c=126 MONO MODE ON (upon reception, Mono Mode is entered, so that only a single voice sounds at a time)	V=0
c=127 POLY MODE ON (upon reception, Poly Mode is entered, enabling multiple voices)	V=0

#### 4-2. System Information

##### 1) System Realtime Message

###### ① Active Sensing

When this message is received, sensing begins. After this, if neither status nor data is received for 400msec or more, the MIDI reception buffer is cleared, and sound production is forcibly stopped.

Status: 11111110 (FEH)

###### ② System Reset

When this is received, all MIDI-related settings are initialized, and ALL NOTES OFF is processed.

Status: 11111111 (FFH)

##### --Contents of Initialization--

OMNI	ON
LOCAL	ON
PROGRAM CHANGE CANCEL	OFF
CONTROL CHANGE CANCEL	OFF

##### 2) System Exclusive Message

###### ① Program Change Dump Request

When this is received, a Program Change Message is sent from the MIDI OUT terminal.

Status: 11110000 (FOH) System Exclusive  
 ID No.: 01000011 (43H) YAMAHA  
 Sub-status: 0010nnnn (2nH) n=0 (channel number 1) - 15 (channel number 16)  
 Format No.: 01111100 (7CH) Universal Bulk Dump Request  
 EOX: 11110111 (F7H)

Function ...	Transmitted	Recognized	Remarks
Basic Default	: 1	: 1	
Channel Changed	: 1 - 16	: 1 - 16	
Mode Default	: 3	: 1	
Mode Messages	: x	: Omni, Mono/Poly	
Mode Altered	: *****	: x	
Note Number : True voice	: 21 - 108 : *****	: 21 - 108 : 21 - 108	
Velocity Note ON	: o 90H, v=1-127	: o v=1-127	
Velocity Note OFF	: x 90H, v=0	: x	
After Key's	: x	: x	
Touch Ch's	: x	: x	
Pitch Bender	: x	: x	
Control Change	64 : o 66 : o 67 : o	: o : o : o	Sustain Key hold Soft pedal
Prog Change : True #	: o 0 - 4 : *****	: o 0 - 127 : 0 - 4	
System Exclusive	: x	: o	
System : Song Pos	: x	: x	
System : Song Sel	: x	: x	
Common : Tune	: x	: x	
System : Clock	: x	: x	
Real Time : Commands	: x	: x	
Aux : Local ON/OFF	: x	: o	
Aux : All Notes OFF	: x	: o (122-127)	
Mes- : Active Sense	: o	: o	
sages: Reset	: x	: o	
Notes			

**YAMAHA**